

RÄUMDORNE PUSH BROACH



Robert-Bosch-Str. 2
D-75233 Tiefenbronn
Telefon: +49 7234 94592-0
Telefax: +49 7234 94592-29
E-Mail: info@stalex.de

RÄUMDORNE „INNENSECHSKANT“ / PUSH BROACH „HEXAGON“ für PCM-Halter, Zürn-/Arno-Halter Werkstoff: HSS 1.3343 - gehärtet

12 x 55 mm

Bestell-Nr Order-No	PCM-Nr.	Zürn- Arno-Nr.	D	L	SW
12x55015S	6150-01,5	12.015	12	55	1,5
12x55020S	6150-02	12.020	12	55	2
12x55025S	6150-025	12.025	12	55	2,5
12x55030S	6150-03	12.030	12	55	3
12x55035S	6150-03,5	12.035	12	55	3,5
12x55040S	6150-04	12.040	12	55	4
12x55050S	6150-05	12.050	12	55	5
12x55060S	6150-06	12.060	12	55	6
12x55014ZS	6150-06,35	12.0635	12	55	1/4"
12x55070S	6150-07	12.070	12	55	7
12x55080S	6150-08	12.080	12	55	8
12x55090S	6150-09	12.090	12	55	9
12x55100S	6150-10	12.100	12	55	10
12x55110S	6150-11	12.110	12	55	11
12x55120S	6150-12	12.120	12	55	12
12x55130S	6150-13	12.130	12	55	13
12x55140S	6150-14	12.140	12	55	14
12x55150S	6150-15	12.150	12	55	15
12x55160S	6150-16	12.160	12	55	16
12x55170S	6150-17	12.170	12	55	17
12x55190S	6150-19	12.190	12	55	19
12x55220S	6150-22	12.220	12	55	22
12x55270S	6150-27	12.270	12	55	27

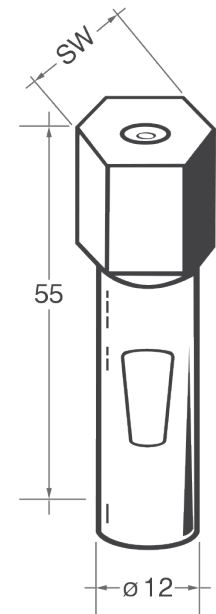

8 x 28 mm

Bestell-Nr Order-No	PCM-Nr.	Zürn- Arno-Nr.	D	L	SW
8x28015S	2110-1,5	08.015	8	28	1,5
8x28020S	2112	08.020	8	28	2
8x28025S	2112-5	08.025	8	28	2,5
8x28030S	2113	08.030	8	28	3
8x28035S	2113-5	08.035	8	28	3,5
8x28040S	2114	08.040	8	28	4
8x28050S	2115	08.050	8	28	5
8x28060S	2116	08.060	8	28	6
8x28014ZS	2116,35	08.0635	8	28	1/4"
8x28070S	2117	08.070	8	28	7
8x28080S	2118	08.080	8	28	8
8x28090S	2119	08.090	8	28	9
8x28100S	21110-10	08.100	8	28	10
8x28120S	2110-12	08.120	8	28	12
8x28140S	2110-14	08.140	8	28	14
8x28170S	2110-17	08.170	8	28	17

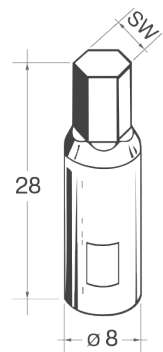

RÄUMDORNE „INNENSECHSKANT“ / PUSH BROACH „HEXAGON“ für PCM-Halter, Zürn-/Arno-Halter Werkstoff: HSS 1.3343 - gehärtet

5 x 20 mm

Bestell-Nr Order-No	PCM-Nr.	D	L	SW
5x20015S	2151-01,5	5	20	1,5
5x20020S	2151-02	5	20	2
5x20025S	2151-025	5	20	2,5
5x20030S	2151-03	5	20	3
5x20040S	2151-04	5	20	4
5x20050S	2151-05	5	20	5
5x20060S	2151-06	5	20	6
5x20070S	2151-07	5	20	7
5x20080S	2151-08	5	20	8

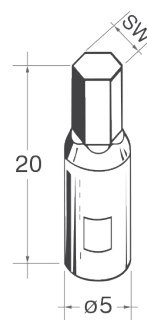

5 x 17 mm

Bestell-Nr Order-No	PCM-Nr.	D	L	SW
5x17020S	2151-2	5	17	2
5x17025S	2151-2,5	5	17	2,5
5x17030S	2151-3	5	17	3
5x17040S	2151-4	5	17	4
5x17050S	2151-5	5	17	5

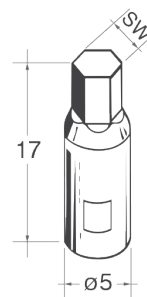

RÄUMDORNE „INNENTORX“ / PUSH BROACH „TORX“ für PCM-Halter, Zürn-/Arno-Halter Werkstoff: HSS 1.3343 - gehärtet

12 x 55 mm

Torx-TIALN-besch.

Bestell-Nr Order-No	D	L	TORX
12x55060T	12	55	T6
12x55070T	12	55	T7
12x55080T	12	55	T8
12x55090T	12	55	T9
12x55100T	12	55	T10
12x55150T	12	55	T15
12x55200T	12	55	T20
12x55250T	12	55	T25
12x55270T	12	55	T27
12x55300T	12	55	T30
12x55400T	12	55	T40
12x55450T	12	55	T45
12x55500T	12	55	T50
12x55550T	12	55	T55
12x55600T	12	55	T60
12x55700T	12	55	T70
12x55800T	12	55	T80

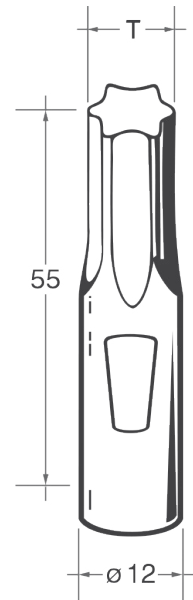

8 x 28 mm

Torx-TIALN-besch.

Bestell-Nr Order-No	D	L	TORX
8x28060T	8	28	T6
8x28070T	8	28	T7
8x28080T	8	28	T8
8x28090T	8	28	T9
8x28100T	8	28	T10
8x28150T	8	28	T15
8x28200T	8	28	T20
8x28250T	8	28	T25
8x28270T	8	28	T27
8x28300T	8	28	T30
8x28400T	8	28	T40
8x28450T	8	28	T45
8x28500T	8	28	T50
8x28550T	8	28	T55

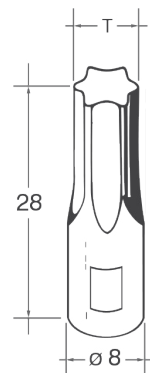

5 x 20 mm

Torx-TIALN-besch.

Bestell-Nr Order-No	D	L	TORX
5x20060T	5	20	T6
5x20070T	5	20	T7
5x20080T	5	20	T8
5x20090T	5	20	T9
5x20100T	5	20	T10
5x20150T	5	20	T15
5x20200T	5	20	T20
5x20250T	5	20	T25

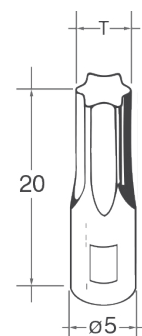

RÄUMDORNE „INNENSECHSKANT“ / PUSH BROACH „HEXAGON“ für INDEX-Halter Werkstoff: HSS 1.3343 - gehärtet

8 x 30 mm

Bestell-Nr Order-No	D	L	L1	L2	SW 6-kt.
8x30015S	8	30	12	18	1,5
8x30020S	8	30	12	18	2
8x30025S	8	30	12	18	2,5
8x30030S	8	30	12	18	3
8x30035S	8	30	12	18	3,5

8x30040S	8	30	15	15	4
8x30050S	8	30	15	15	5
8x30060S	8	30	15	15	6
8x30070S	8	30	15	15	7
8x30080S	8	30	15	15	8
8x30090S	8	30	15	15	9
8x30100S	8	30	15	15	10
8x30120S	8	30	15	15	12
8x30140S	8	30	15	15	14

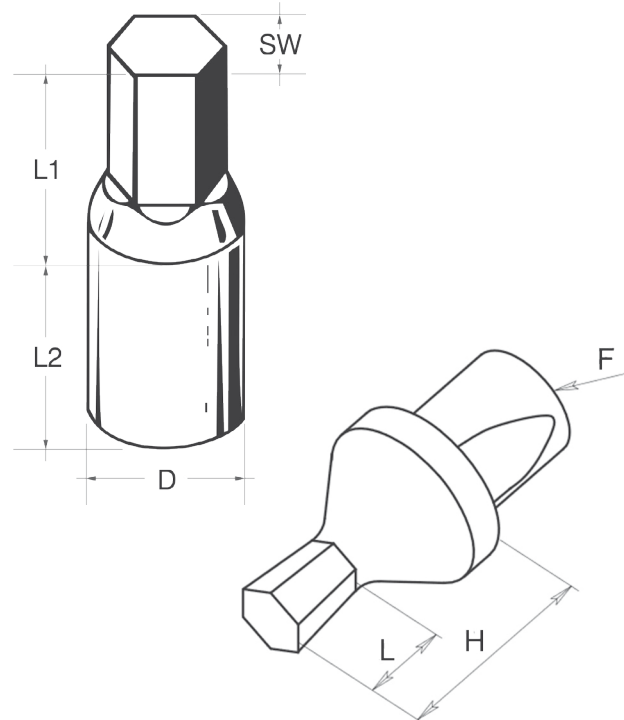

12 x 40 mm

Bestell-Nr Order-No	D	L	L1	L2	SW 6-kt.
12x40015S	12	40	15	25	1,5
12x40020S	12	40	15	25	2
12x40025S	12	40	15	25	2,5
12x40030S	12	40	15	25	3
12x40018ZS	12	40	15	25	1/8"
12x40035S	12	40	15	25	3,5
12x40040S	12	40	15	25	4

12x40050S	12	40	18	22	5
12x40060S	12	40	18	22	6
12x40014ZS	12	40	18	22	1/4"
12x40070S	12	40	18	22	7
12x400516ZS	12	40	18	22	5/16"
12x40080S	12	40	18	22	8
12x40090S	12	40	18	22	9
12x40038ZS	12	40	18	22	3/8"
12x40100S	12	40	18	22	10
12x40110S	12	40	18	22	11
12x40120S	12	40	18	22	12
12x40012ZS	12	40	18	22	1/2"
12x40130S	12	40	18	22	13
12x40140S	12	40	18	22	14
12x40150S	12	40	18	22	15
12x40160S	12	40	18	22	16
12x40170S	12	40	18	22	17
12x40190S	12	40	18	22	19
12x40220S	12	40	18	22	22
12x40240S	12	40	18	22	24
12x40270S	12	40	18	22	27
12x40320S	12	40	18	22	32

16 x 59 mm

Bestell-Nr Order-No	F	H	SW 6-kt.
16x59030S	16	40	3
16x59035S	16	40	3,5
16x59040S	16	40	4
16x59050S	16	40	5
16x59060S	16	40	6
16x59070S	16	40	7
16x59080S	16	40	8
16x59090S	16	40	9
16x59100S	16	40	10
16x59110S	16	40	11
16x59120S	16	40	12
16x59130S	16	40	13
16x59140S	16	40	14
16x59150S	16	40	15
16x59160S	16	40	16
16x59170S	16	40	17
16x59180S	16	40	18
16x59190S	16	40	19
16x59200S	16	40	20
16x59210S	16	40	21
16x59220S	16	40	22
16x59230S	16	40	23
16x59240S	16	40	24
16x59250S	16	40	25

RÄUMDORNE „INNENTORX“ / PUSH BROACH „TORX“ für INDEX-Halter Werkstoff: HSS 1.3343 - gehärtet

8 x 30 mm

Torx-TIALN-besch.

Bestell-Nr Order-No	D	L	L1	L2	Torx
8x30060T	8	30	15	15	T6
8x30070T	8	30	15	15	T7
8x30080T	8	30	15	15	T8
8x30090T	8	30	15	15	T9
8x30100T	8	30	15	15	T10
8x30150T	8	30	15	15	T15
8x30200T	8	30	15	15	T20
8x30250T	8	30	15	15	T25
8x30270T	8	30	15	15	T27
8x30300T	8	30	15	15	T30
8x30400T	8	30	15	15	T40
8x30450T	8	30	15	15	T45
8x30500T	8	30	15	15	T50
8x30550T	8	30	15	15	T55

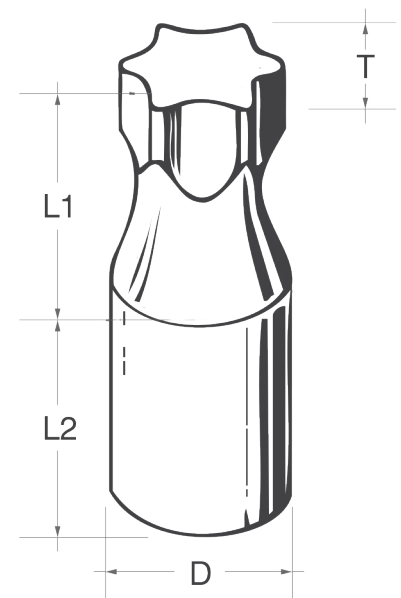

12 x 40 mm

Torx-TIALN-besch.

Bestell-Nr Order-No	D	L	L1	L2	Torx
12x40060T	12	40	20	20	T6
12x40070T	12	40	20	20	T7
12x40080T	12	40	20	20	T8
12x40090T	12	40	20	20	T9
12x40100T	12	40	20	20	T10
12x40150T	12	40	20	20	T15
12x40200T	12	40	20	20	T20
12x40250T	12	40	20	20	T25
12x40270T	12	40	20	20	T27
12x40300T	12	40	20	20	T30
12x40400T	12	40	20	20	T40
12x40450T	12	40	20	20	T45
12x40500T	12	40	20	20	T50
12x40550T	12	40	20	20	T55
12x40600T	12	40	20	20	T60

16 x 59 mm

Torx-TIN-besch.

Bestell-Nr Order-No	F	H	Torx
16x59100T	16	40	T10
16x59150T	16	40	T15
16x59200T	16	40	T20
16x59250T	16	40	T25
16x59270T	16	40	T27
16x59300T	16	40	T30
16x59400T	16	40	T40
16x59450T	16	40	T45
16x59500T	16	40	T50
16x59550T	16	40	T55

